

LED WET LOCATION EM UNIT (LSWL)



HOUSING

- Impact Resistant 94-5VA polycarbonate
- Gasketed and Sealed Hinged Cover
- Cold Weather (-20°C) Standard
- Gray Finish Standard

ILLUMINATION

- Fully Adjustable 1.9watt LED Nema Rated Lamp Heads

BATTERY

- Maintenance Free 6 Volt NiCad Battery Standard
- Remote Capable up to 3.7 Watt in temperatures ranging from 0°-50°C - Powers up to (2) PRLed Remote Heads
- 90 Minute Run Time, 24Hr Recharge Time

ELECTRONICS

- Charge Rate/Power On LED Indicator Light with Test Button
- Overload and Short-circuit Protection
- Low voltage Disconnect
- Brown-out Protection
- 120-277 Volt Rated, 60Hz Input

CODE CONFORMANCE & STANDARDS

- UL 924 N.E.C, N.F.P.A. 101
- IP65 Rated



DIMENSIONS

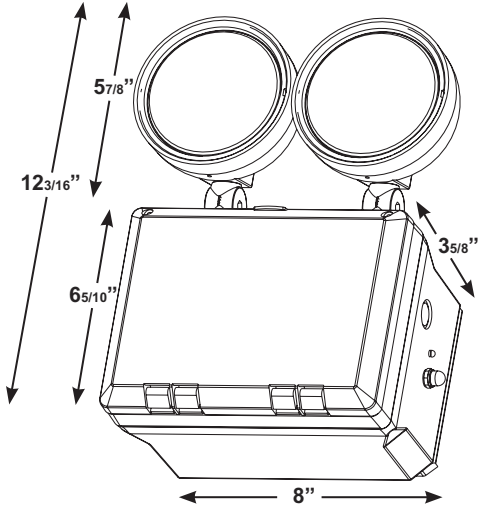

Wire guard available. Order separately.
See wire guard chart in Accessories section.

ORDERING INFORMATION

TYPICAL ORDER EXAMPLE: **LSWL GY**

Prefix	Finish	Accessories
LSWL	BK - Black GY - Gray	VL - Vandal Guard (back mount)